

CHECK EITHER WITH OR WITHOUT LIGHTS

Fountain Only									
With LED Lights									
Motor HP	2	2	2	3	3	3	5	5	5
Volts	230	230	208	230	230	208	230	230	208
Phase	1	3	3	1	3	3	1	3	3
AMP	14	8	9	17	10	13	28	17	21
HT. A	6'	6'	6'	7'	7'	7'	8'	8'	8'
Dia. B	25'	25'	25'	30'	30'	30'	35'	35'	35'
43W LED Lights	3	3	3	3	3	3	3	3	3
Total Watts	86	86	86	86	86	86	86	86	86
AMP Draw	0.8	0.8	0.8	0.8	0.8	0.8	0.8	0.8	0.8

Drawings are for illustration only and not to scale. Installation of fountain equipment shall be in accordance with manufacturers specifications.

FLOTATION SYSTEM

Rotocast polypropylene with ultraviolet inhibitors added for extended protection against warping/cracking.

PUMP/MOTOR

____ HP, ____ Volt, ____ Phase stainless steel, sealed UL listed submersible motor. Submersible turbine pump shall be of 100% 304 stainless steel construction, with driveshaft of 416 stainless steel and equipped with sand collars for maximum protection against abrasives. Pump and motor are water cooled and lubricated. *Use of oil-filled motors/pumping systems are not acceptable due to need for regular replacement of oil, O-rings, and seals.*

INTAKE SCREEN

Type 304, 18ga stainless steel, protects against foreign material entering pumping system.

FRAMEWORK

Type 304 stainless steel with welded joints and stainless steel fastenings.

LIGHTING FIXTURES

____ 43watt, 120V clear LED lamps housed in stainless steel fixtures with tempered lens and neoprene gaskets, mounting brackets and fastenings of stainless steel. See specification chart for suggested lighting package. ETL listed.

DISPLAY HEAD

Head shall be constructed of stainless steel.

UNDERWATER ELECTRICAL CABLES

STW-A rated, stamped "water resistant". ____' of ____ga-motor, ____' of ____ga-lights

FOUNTAIN CONTROL PANEL

- ◆ Steel NEMA 3R enclosure
- ◆ Surge/Lightning Protection
- ◆ Capacitive motor starter (single phase units)
- ◆ 2 - 24 hour time clocks
- ◆ Phase loss protection (3-phase units)
- ◆ Circuit breaker - pump
- ◆ Circuit breaker - lights (if equipped)
- ◆ GFI protection - pump
- ◆ GFI protection - lights (if equipped)

WARRANTY (PARTS)

- ◆ Fountain - 4 years
- ◆ Light Fixtures (excludes bulbs) - 2 years
- ◆ Controls - 1 year

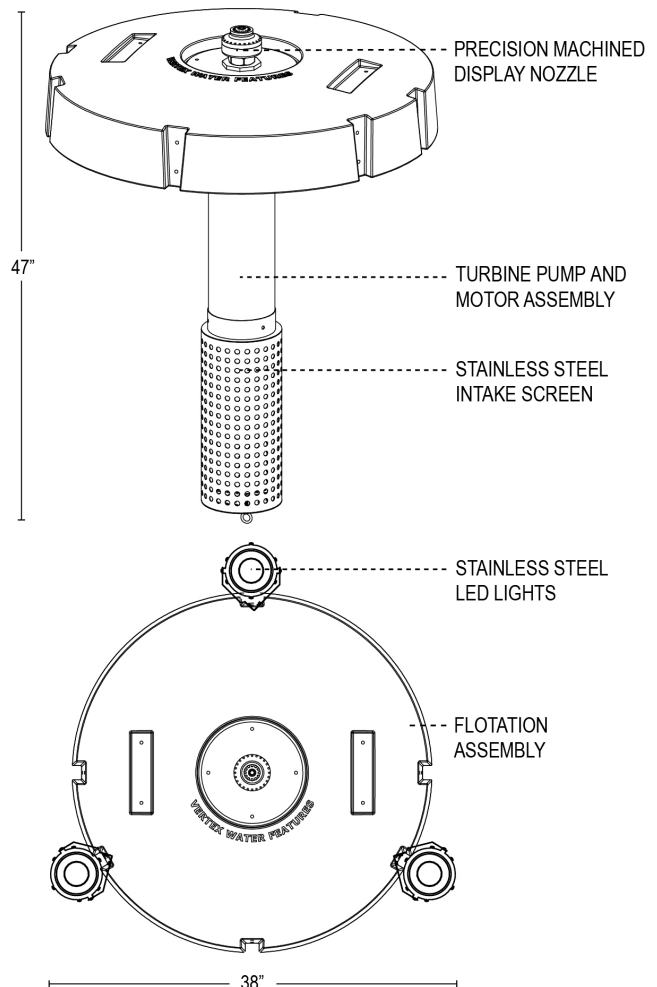

*Vertex reserves the right to improve and change designs and/or specifications without notice or obligation.

FOUNTAIN CONTROL PANEL

Warning - The fountain control panel must be installed by licensed electrician in accordance with article 682 of national electrical code.

Panel location is above any and all possible high water levels. Submergence of panel poses serious risk of electrical shock and damage of fountain system. Failure may result in potentially hazardous conditions and/or failure of electrical inspection.

Consult authorities having jurisdiction (ahj) for specific local codes/restrictions. Vertex Aquatic Solutions accepts/assumes no responsibility for installations not in accordance with local and/or national electrical codes.

SCOPE OF WORK - ELECTRICIAN

1. Mount NEMA 3R panel enclosure in accordance with NEC 682 following any additional local codes and/or restrictions that exist.
2. Trench and bury sufficiently sized conduit(s) from fountain panel to water's edge, extending conduit(s) far enough into water to insure no submersible cable is exposed should low water conditions arise.
3. Bring incoming power from power source into the fountain panel. Incoming voltage must match with specifications of fountain panel or failure will result, damaging the system and voiding the warranty.
4. Pull submersible cable(s) from fountain through conduit to control panel and perform final connections

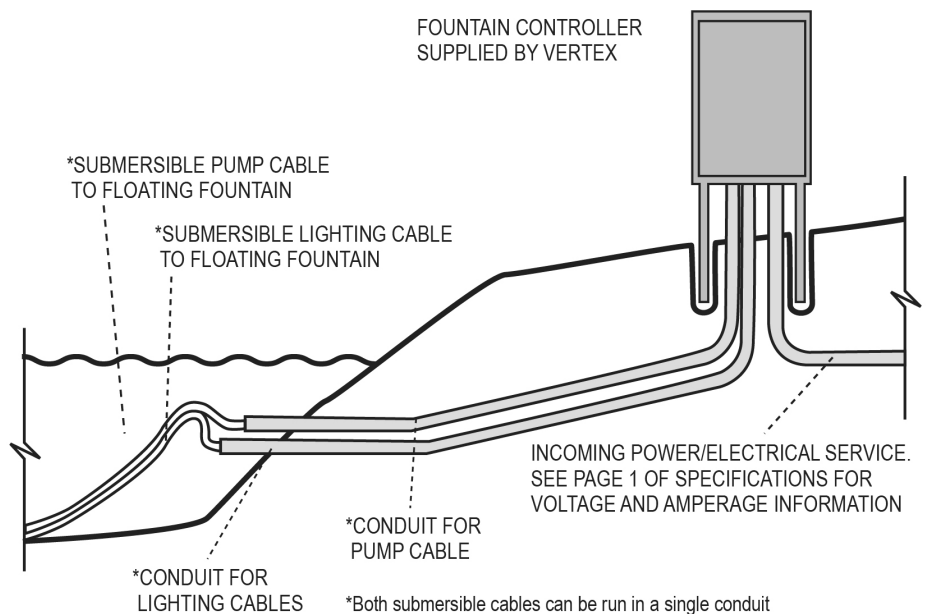

See Fountain Owner's Manual for details on installing the fountain in your lake.

IMPORTANT NOTES

Do not operate fountain and lights until fountain installation has been completed and lights are fully submerged.

Operating light(s) out of water will result in damage to bulb(s) and lens(es), voiding manufacturer's warranty.

Connect only 120V to light(s)

Higher voltage will result in immediate damage or failure of bulb(s).

