



220V-240V Aeration Owner's Manual Outside the US and Canada

1.844.432.4303

vertexaquaticsolutions.com | info@vertexaquaticsolutions.com

Hours of Operation: M-F, 8am-5pm EST

© Vertex Aquatic Solutions

- | | |
|-------------------------------|--------------------------|
| 2 Aeration Goals | 6 System Start-up |
| 2 Warranty | 7 Installation Steps |
| 2 Product Damaged in Delivery | 8 Maintenance |
| 3 System Materials List | 9 Winter Operations |
| 4 Safety | 10 Compressor Diagram |
| 5 Cabinet & Compressor | 11 Troubleshooting Guide |
| 6 AirStation™ Installation | 12 Maintenance Log |
| 6 AirStation™ Balancing | 12 Parts List |





1.844.432.4303

vertexaquaticsolutions.com

info@vertexaquaticsolutions.com

M-F, 8am-5pm EST

© Vertex Aquatic Solutions

CONGRATULATIONS!

You have purchased the most efficient and cost-effective aquatic aeration system available on the market today. The professionals at Vertex Aquatic Solutions, a Rentokil Company have been developing total lake management techniques for over 30 years. With regular maintenance, your new Vertex system will provide your waterbody with the oxygen it needs for years to come.

CHECK MATERIALS UPON DELIVERY

FOR PRODUCT DAMAGED IN DELIVERY

The aeration system was properly packed and accepted by the freight carrier for shipment. It is therefore their responsibility to deliver the system in perfect condition.

FOR APPARENT DAMAGE OR LOSS

If the equipment or containers indicate DAMAGE IN TRANSIT, such goods should be refused or not accepted until the transportation company's agent has noted such on the freight bill. A copy of such bill will be given to you, noting the nature and extent of the damage. If any part of shipment is LOST IN TRANSIT, have the shortage noted on the freight bill by agent.

FOR CONCEALED DAMAGE

If damage is discovered, that was not apparent upon delivery, notify the transportation company immediately to inspect damaged equipment. The inspector will be required to provide a "CONCEALED BAD ORDER" report. Inspections must be requested within 15 days of delivery. Do not move damaged goods from original point of delivery. Retain all original packing and containers for inspection. File a "FULL VALUE REPLACEMENT" claim against the transportation company.

SYSTEM MATERIALS LIST

Verify that you received the following:

- ◆ QuietAir™ Compressor Cabinet with Poly Plastic Mounting Pad: the cabinet houses the compressor(s), inlet filter/muffler assembly, air outlet hose, and ventilation fan.
- ◆ Compressor with Valve Manifold or remote valve box manifold: **Make sure you received the correct type.**
- ◆ AirStations™: **Check to make sure you have the correct type and quantity based upon your order.** Please refer to your invoice or packing slip for reference.
- ◆ Tubing: **Check to make sure you have the correct type and quantity of tubing based on your order along with the parts for installation.**

PRODUCT WARRANTY

Vertex Aquatic Solutions will repair or replace any defective part within the compressor cabinet for a period of 3 years from date of receipt. The AirStation™ diffuser assembly will be warranted for a period of 5 years and BottomLine™ tubing will be warranted for a period of 15 years. Air filters and compressor maintenance kits are wearable parts and not covered under this warranty.

The customer is responsible for return shipping of any goods for warranty inspection by Vertex Aquatic Solutions. After inspection, if the product shows manufacturing defect, Vertex will repair or replace it at no cost to the customer. Should inspection indicate non-warranty failure (incorrect voltage, faulty installation procedures, vandalism, customer negligence, etc.) warranty will be voided. Painting the cabinet will cause the internal components to overheat and void the warranty. Water intrusion will also void the warranty.

The warranty period for all warranty work is equal to the remaining time period of the original new equipment warranty. Warranty claims are based on the date you notify your dealer or Vertex Aquatic Solutions at 844-432-4303. All claims must be made to Vertex Aquatic Solutions or an Authorized Vertex Dealer.

NOTE: Vertex reserves the right to change this information without notice, and makes no warranty, express or implied, with respect to this information. Vertex shall not be liable for any loss or damage, including consequential or special damages, resulting from the use of this information, even if loss or damage is caused by Vertex negligence or other fault.

WARNING/ATTENTION

Installing this aeration system in any of the following ways will void your 3 year compressor system warranty. L'installation de ce système d'aération sans appliquer les recommandations suivantes annulera votre garantie 3 ans sur le compresseur.

Installing the cabinet inside a box, shed or other enclosure that traps the cabinet exhaust heat and rapidly overheats the compressor and motor. Installation de l'armoire dans une boîte, un hangar ou tout autre dispositif de pièges à chaleur de l'armoire d'échappement et rapidement surchauffer le compresseur et le moteur.

Providing undersized electrical supply wires that can't maintain required voltage when compressor is running under load causes high electrical resistance, severe compressor vibration and premature motor failure and compressor head damage. Lignes électriques plus petits qui ne peuvent pas maintenir les volts nécessaire lorsque le compresseur est en marche sous charge des causes de haute résistance électrique, les vibrations de l'échec du moteur du compresseur et de graves dommages prématurés à la tête du compresseur.

Painting the cabinet exterior elevates interior cabinet temperatures and damages the motor and compressor. Peindre l'extérieur de l'armoire système va augmenter sa température intérieure et entraîner des dommages au moteur et compresseur.

Installing a cabinet in a very low elevation where flooding may occur. Water entering the cabinet will destroy the motor, compressor, cabinet fan(s) and GFCI receptacle. Ne pas installer l'armoire système dans une zone basse où les inondations peuvent se produire. L'eau endommagera le moteur, le compresseur, le compartiment du ventilateur (s) et du réceptacle GFCI.

Installing the cabinet in an unusually dirty environment. Excessive airborne dirt, sand or grit entering the cabinet will damage the motor and compressor. Installer l'armoire système dans une zone très sale (excès de matières en suspension dans l'air, sable, gravier) dans endommagera le moteur et le compresseur.

Call your dealer or Vertex Aquatic Solutions for help resolving installation problems. Appelez votre revendeur ou l'eau Caractéristiques de Vertex pour des problèmes aide à l'installation.

SAFETY NOTES

Please read the following instructions carefully before installing and operating your aeration system. Failure to follow the recommendations in this section may result in personal injury or rescinding of the machine warranty agreement.

WARNING/ATTENTION

- ◆ Risk of electric shock - this pump is supplied with a grounding conductor and grounding-type attachment plug. To reduce risk of electric shock, be certain that it is connected only to a properly grounded, grounding-type receptacle. *Risque d'électrocution – Cette pompe est équipée d'un câble d'alimentation en 220V comprenant un fil de terre et d'une prise de courant équipée d'une prise de terre. La prise doit être branchée sur une alimentation correctement installée et reliée à la terre suivant la réglementation en vigueur.*
- ◆ An improper connection to the aerator grounding conductor can result in electrical shock. *Une connexion incorrecte du conducteur de terre à l'aérateur peut entraîner un choc électrique.*
- ◆ The appliance is not to be used by children or persons with reduced physical, sensory or mental capabilities, or lack of experience or knowledge, unless they have been given supervision or instruction. *L'appareil ne doit pas être utilisé par des enfants ou des personnes qui n'ont pas le physique, la capacité sensorielle ou mentale, ou de l'expérience ou de connaissance, sauf si elles ont la surveillance ou d'instructions.*
- ◆ Children being supervised are not to play with the appliance. *Les enfants sont encadrés ne sont pas à jouer avec l'appareil.*

ELECTRIC INSTALLATION INSTRUCTIONS

- ◆ Contract a licensed electrical contractor
- ◆ The unit is built as a cord-connected product only
- ◆ The unit is rated for 230V Single Phase
- ◆ The unit does not provide a GFCI receptacle
- ◆ The complete circuit must be protected by a 2-pole 20 amp GFCI breaker rated for 230V
- ◆ Unit must be plugged into an electrical approved receptacle having 6-20R configuration
- ◆ Receptacle must be 20A resistive and protected by a weatherproof cover
- ◆ Use an adequate wire gauge from breaker to receptacle to prevent a voltage drop at the connection

GROUNDING INSTRUCTIONS

This product must be grounded. In the event of an electrical short circuit, grounding reduces the risk of electric shock by providing an escape wire for the electric current. This product is equipped with a cord having a grounding wire with an appropriate grounding plug. The plug must be plugged into an outlet that is properly installed and grounded in accordance with all local codes and ordinances.

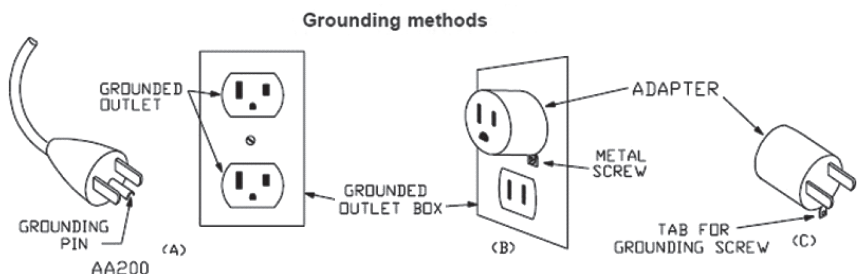

WARNING/ATTENTION

Improper installation of the grounding plug is able to result in a risk of electric shock. When repair or replacement of the cord or plug is required, do not connect the grounding wire to either flat blade terminal. The wire with insulation having an outer surface that is green with or without yellow stripes is the grounding wire. *Une installation incorrecte de la prise de terre peut provoquer un choc électrique. Lorsque la réparation ou le remplacement du cordon ou la fiche est nécessaire, ne pas connecter le fil de terre à la borne à lame plate. Le fil avec isolation ayant une surface extérieure qui est verte, avec ou sans rayures jaunes, est le fil de terre.*

- ◆ Always connect the cabinet to a properly grounded outlet. If in doubt, have the outlet checked by a qualified electrician.
- ◆ Never use an extension cord between the cabinet power cord and an electrical outlet.
- ◆ Do not allow anything to rest on the power cord.
- ◆ Do not place the cabinet where people may step or trip on the power cord.
- ◆ Follow all warnings and instructions that are marked on or supplied with the aeration system.
- ◆ Never override or “cheat” electrical or mechanical interlock devices.
- ◆ Always locate the cabinet on a solid support with adequate strength for the weight of the unit.
- ◆ Install the cabinet at a distance and location safe from standing water or flooding per National Electric Code 682 and all local codes.
- ◆ Locate the cabinet away from irrigation sprinklers.
- ◆ Never push objects of any kind into the slots in the covers, as they may touch dangerous voltage points or short out parts that could result in a risk of fire or electrical shock.
- ◆ Never attempt any maintenance function that is not specified in the user manual.
- ◆ Never remove any covers or guards that require a tool for removal, unless you are instructed to do so. Ensure that you read all Warnings and Cautions, and follow each step in the instructions exactly as they are written.
- ◆ Never attempt any activity that is not specified in the user manual, or that is not specifically directed by an authorized Vertex representative.
- ◆ Never operate the system if unusual noises or odors are detected. Turn system off at disconnect switch and call Vertex to correct any problems.
- ◆ If the supply cord is damaged, it must be replaced by the manufacturer, its service agent or similarly qualified persons in order to avoid a hazard.
- ◆ Before performing any maintenance and troubleshooting, disconnect the electricity by turning off disconnect switch or unplug the unit.
- ◆ When in or around water, wear a Coast Guard approved life jacket and follow all water safety guidelines.
- ◆ Refer to these instructions as needed in order to ensure the safe operation of the aerator.

WARNING/ATTENTION

Drowning warning: Operating in freezing conditions on an ice-covered lake will cause large open water areas to remain at the boil sites. The ice thickness around these open areas will be much thinner than the ice over the rest



of the lake. Injury or fatality may result from falling through the ice. Vertex strongly recommends that this danger of thin ice around the boil area be clearly posted at frequent intervals. Owner assumes all responsibility for operating Vertex aeration systems during winter months. **Noyade attention:** exploitation dans des conditions de congélation sur un couvert de glace du lac causera de grandes zones d'eau libre de rester sur les sites ébullition. L'épaisseur de la glace autour de ces zones

ouvertes seront beaucoup plus mince que la glace sur le reste du lac. Blessure ou décès peuvent résulter de la chute à travers la glace. Vertex recommande fortement que ce danger de glace mince autour de la zone ébullition être clairement affichés à intervalles fréquents. Propriétaire assume toute la responsabilité pour le fonctionnement des systèmes d'aération Vertex pendant les mois d'hiver.

CABINET INSTALLATION GUIDELINES

- ◆ Your cabinet was shipped with a plastic mounting pad attached. You may use this pad for the final installation and/or use a cement pad in areas where vandalism is a potential problem.
- ◆ For proper cooling, cabinet must have a minimum clearance of 1' (one foot) around the unit's perimeter.
- ◆ To use the plastic pad: clear the ground of any rocks, sticks and debris that will prevent the pad from sitting flat. You may need to use a shovel to level the ground to achieve this. Check the final placement with a level.
- ◆ To minimize compressor noise, place cabinet directly on the ground, surrounded by landscaping.
NOTE: Place the pad so that the air lines leaving the cabinet face the lake.
- ◆ Using this method, the cabinet installation is now complete.

IF A CEMENT PAD IS REQUIRED

- ◆ A wooden form must be built to pour a pad. Place the cabinet and plastic pad on the ground in the location that you want it.
- ◆ Dig out around the pad using the pad as an outline, Dig the hole 3" (8 cm) deep. Insert your form into the hole leaving at least 1" (2.5 cm) of wood form above the ground level when complete.
- ◆ Mix the concrete and pour it up to the top of the form. Using a trowel, skim the top for a nice finish. The concrete should set within 48 hours, colder climates may take longer.
- ◆ Once the concrete has cured, simply take the cabinet and plastic mounting pad and place them on top of the cement pad. Drill four holes, one in each corner of the plastic pad using a masonry drill bit.
- ◆ Insert a wedge anchor through the plastic pad and into the cement. Using the nut and washer supplied with the anchor kit (purchased separately), fasten the plastic pad to the cement pad you made.
- ◆ Contract a licensed electrical contractor to bring 115, single phase electrical supply to the cabinet and install a weatherproof receptacle.

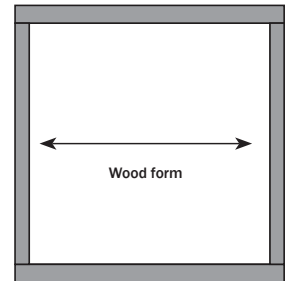

AIRSTATION INSTALLATION

Correct placement is critical: the ability of the system to affect your waterway depends on the position of the diffuser. It should be placed in the deepest areas of the water body. To make installation easier you should know where you intend to place the diffuser before starting the installation process.

STOP WARNING/ATTENTION

When in or around water always wear an approved life jacket and follow all water safety guidelines. Lorsque dans ou autour de l'eau toujours porter un gilet de sauvetage approuvé et suivez toutes les consignes de sécurité de l'eau.

Materials for set-up: the AirStation, Waterproof PVC glue or a screw driver and hose clamp, a utility knife, and enough rope to reach the lake bottom and back: 10' (3.0 m) depth = 20' (6.1 m) rope).

- ◆ Once you have returned to shore, attach the open end of the supply tubing to the hose coming out of the compressor cabinet via the barbed fitting.
- ◆ Secure and tighten stainless steel clamps to both supply tubing and compressor hose.
- ◆ Trench and bury supply tubing runs from compressor cabinet to water's edge.

AIRSTATION INSTALLATION - Following these steps to prevent inverting.

XL4 or XL5 AirStations follow 1a-1c



Fill the base up with river rock or gravel. Do not use sand. **After filling, pick up at base only.**

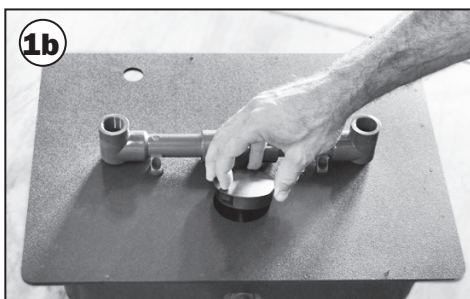

Insert the plug and the airline hose adapter

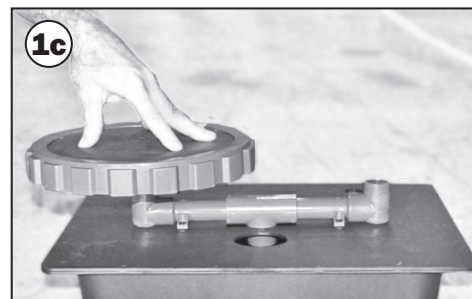

DO NOT USE TEFLON TAPE! Screw diffuser discs onto riser pipes, do not cross thread. **DO NOT OVER TIGHTEN DISK.**

Self-sinking start at 1



DO NOT USE TEFLON TAPE! Screw diffuser discs onto riser pipes, do not cross thread. **DO NOT OVER TIGHTEN DISK.**



Assemble all the materials you will need on the boat - see list above. Pick up airstation by black base only.



Uncoil supply tubing along the shore, making sure tubing is not twisted or tangled. Leave 4' tubing on shore and **secure one end** of the tubing so that it doesn't follow you into the water.

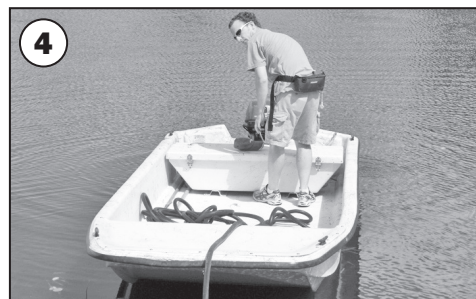

Head out with the other end of the tubing. **Make sure the propeller and tubing do not get tangled up.**



At the drop site, connect the tubing to the barbed fitting. Use PVC cement and let dry (recommended method), **or...**



Connect the tubing to the barbed fitting with a stainless steel hose clamp.

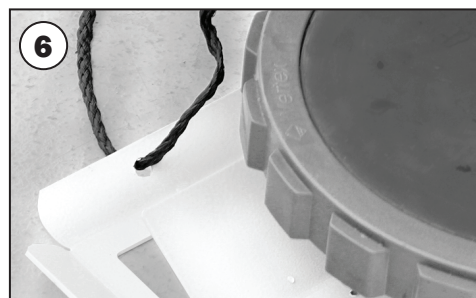

Thread rope through the two holes on the base until the rope is evenly distributed. If Airstation may be moved later on, tie one end of rope to the unit and, after it settles, tie the other end to a buoy or decoy on the surface of the water.

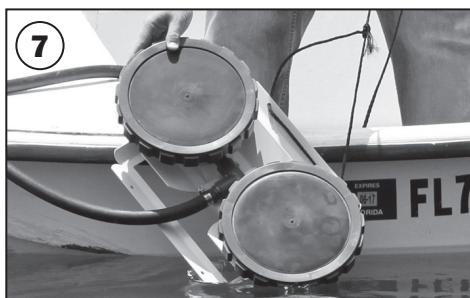

Holding both ends of the rope in your hand, lower the diffuser assembly into the water. Once unit is on lake bottom, release one end of the rope and pull rope into the boat.

Follow the start-up procedures on page 8

AIRSTATION™ BALANCING

Once the installation of a multiple AirStation system has been completed, proper balancing of the AirStations is required to ensure that they all get an equal amount of air. The control valves for each AirStation are located inside the cabinet, unless a Remote Valve Box System (VBS) was installed. In the instance that a VBS was installed, the control valves will be inside the valve box, buried to ground level, down by the shoreline.

- ◆ Close all blue AirStation valves except the one with the longest (or deepest) run of tubing.
- ◆ With this one valve wide open, partially open the valve that controls the air flow to the AirStation with the second longest (or second deepest) run of tubing.
- ◆ Continue this process of adjusting the second valve until a boil is noticed above this AirStation.
- ◆ Leave the valve in this position and move on to the next valve and repeat the process.
- ◆ Continue working your way from the longest (or deepest) to the shortest (or most shallow) run of tubing.
- ◆ Once there is air to all of the AirStations, check to be sure all boils are approximately the same size.
- ◆ If they are not, make small adjustments as necessary to even them out.
- ◆ At this point, we suggest making indicator marks with a permanent marker from the valve handle to the valve body to assist you in rebalancing the system in the future.
- ◆ The overall goal when adjusting the valves is to balance the AirStation at the lowest possible pressure. The lower the system pressure the higher the total air flow.

WARNING/ATTENTION

If the system has been installed in an established pond and you are attempting to balance the AirStations during the first day of operation, make certain that this procedure takes as little time as possible. *Si vous installez un système dans un ancien étang, et que vous essayez d'équilibrer les AirStation™ lors de la première journée d'opération, assurez-vous que cette procédure prendra le moins de temps possible.*

- ◆ Under 30 minutes is preferred. *Moins de 30 minutes si possible.*
- ◆ See "System Start-up Procedures" section for details. *Voir "Procédures du système de départ" pour plus de détails.*

FIRST TIME AND SPRING START-UP PROCEDURE

Aeration systems circulate the lake's entire water column. The aeration system will circulate deep, poor quality water that accumulates over time upward to the lake's surface introducing harmful gasses into the previously healthy upper regions of the water column. This movement of water can temporarily affect aquatic life and could result in a fish kill.

NOTE: These start-up procedures are a general guideline. If you should have any questions and/or concerns, contact Vertex Aquatic Solutions at 844-432-4303 for technical assistance.

To prevent a fish kill, Vertex has established the following start-up procedures, this should take 7 days:

- ◆ Turn on system and operate for 30 minutes.
- ◆ Turn off system for remainder of the day.
- ◆ Restart the system the next day and operate for 60 minutes. Turn off system for the remainder of day.
- ◆ Each day double the operating time from the previous day until the system is running continuously.

MAINTENANCE/CLEANING INSTRUCTIONS

WARNING/ATTENTION

- ◆ Disconnect unit from electrical supply circuit at disconnect switch before opening. *Débranchez le cabinet du circuit d'alimentation en utilisant l'interrupteur de déconnexion avant l'ouverture*
- ◆ Always use parts that are supplied or approved by Vertex. Use of other parts may result in poor performance and could create a hazardous situation and void the warranty. *Toujours utiliser des pièces qui sont fournis ou approuvés par Vertex. Utilisez d'autres pièces peut entraîner de mauvaises performances et pourrait créer une situation dangereuse et annuler la garantie.*
- ◆ Do not use oil, acid or corrosive cleaners. Follow instructions in manual for the appropriate cleaning methods. *N'utilisez pas de nettoyeurs à l'huile, acides ou corrosifs.. Suivez les instructions dans le manuel pour les méthodes de nettoyage approprié.*
- ◆ Refer servicing to a qualified electrician under the following conditions. *Confiez l'entretien à un électricien qualifié dans les conditions suivantes:*
 - ◆ When the power cord is damaged or frayed. *Lorsque le cordon d'alimentation est endommagé ou effiloché*
 - ◆ When compressor fan, outlet or other electrical components need service. *Ventilateur du compresseur, de sortie ou d'autres composants électriques besoin de service*
 - ◆ If the cabinet is producing unusual noises or odors. *Si le coffret est produisant des bruits ou des odeurs inhabituels*

Vertex aeration systems are designed for low-maintenance and typically only require minimal scheduled maintenance. Periodic cleaning and/or replacement of the compressor air filter, piston cup, and “Flexing” of the AirStation™ is required.

Remember to keep cabinet air inlets and outlets free of debris and weed growth to allow normal ventilation. If size and appearance of any surface boil has decreased from initial installation, perform one or both of the following maintenance procedures.

GENERAL CABINET CLEANING

- ◆ Disconnect unit from electrical supply circuit at disconnect switch prior to opening
- ◆ Using a portable vacuum or rag, remove debris, grass clippings and dirt from inside cabinet
- ◆ Remove objects blocking the cabinet intake vents
- ◆ Remove objects blocking the fan exhaust vent
- ◆ Lubricate the locking mechanism
- ◆ Lubricate cabinet hinges
- ◆ Open the valves that were previously closed.
- ◆ Close the lid and turn on the system for two minutes
- ◆ Return all valves to their original, balanced positions by aligning the marks you made on the valve bodies before starting the procedure.

AIR FILTER CLEANING/REPLACEMENT

Air filter cleaning or replacement: Remove compressor air intake filter and wash with soap and water or replace. This should be done 2-4 times per year. Never re-install a wet or damp filter.

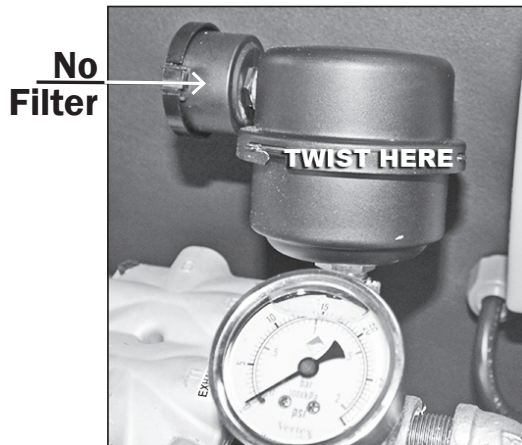

1 Twist to unlock air filter

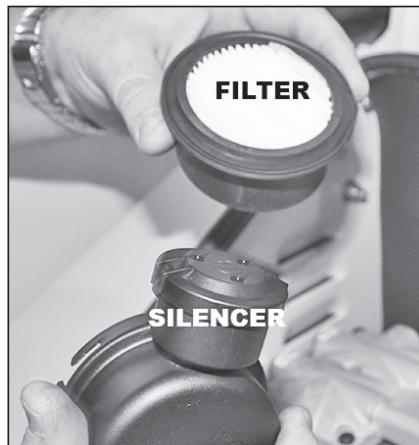

2 Remove old air filter
Insert new air filter

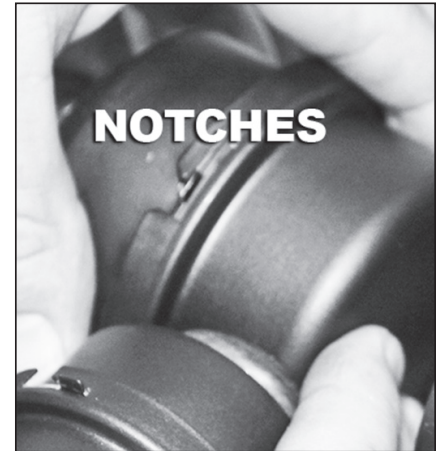

3 Line up the notches
Twist to lock

On the inside of the cabinet lid or the outside back cover of this Owner's Manual, you will find a Vertex parts list that provides you the necessary parts information for ordering replacement parts. Call Vertex at 844-432-4303 with your 4 digit system warranty number or serial number off of the silver ETL sticker, found inside the cabinet. Vertex can also supply you with the necessary replacement parts information.

PISTON CUP REPLACEMENT

Under normal year-round, continuous use, the compressor piston cups typically last 12-36 months depending upon the environmental conditions. As the piston cups wear out, you'll notice a drop in air flow (despite air filter replacement) resulting in smaller surface boils.

CABINET COOLING FAN REPLACEMENT

Cooling fans provide critical cooling for the cabinet components. If the cooling fans fail, cabinet temperatures will drastically increase and damage the compressor system.

For systems that run continuously, we recommend replacing the cooling fans every two or three years during compressor maintenance.

DISK FLEX-CLEANING PROCEDURES

Routine maintenance of the AirStation™ disks is recommended once per year. This procedure is known as disk flexing. Over time organic matter and algae can settle on the AirStations™ and inhibit the release of micro-bubbles, in turn reducing the effectiveness of the AirStation™.

Disk flexing helps unclog the pores in the membranes, reduces back pressure on the compressor(s), and restores the performance of the AirStation™.

Disk flexing is very easy and is done from the cabinet valve manifold or valve box manifold location.

Open the cabinet and make a line with a permanent marker on each valve body and handle that line up with each other in the valve's present position. This will help re-balance the system once you finish flex cleaning the disks.

- ◆ Turn off the power or unplug the system.
- ◆ Close some of the valves, allowing the airflow to be directed to a couple of airstations at a time.
- ◆ Close the lid and turn on the system for two minutes.
- ◆ Turn off the power and unplug the cabinet and close the valves that were just flexed.
- ◆ Close different valves and proceed in the same manner until all of the airstations have been flexed.
- ◆ If you have not yet balanced the AirStations, or cannot read your indicator marks, see the “AirStation™ Balancing” section. The Disk Flex Cleaning procedure is now complete.

OPERATING THE SYSTEM IN THE WINTER

Vertex Aeration Systems are designed to operate year-round in cold climates with these important precautions. If you choose to run the aeration through the winter:

WARNING/ATTENTION



Drowning warning: Operating in freezing conditions on an ice-covered lake will cause large open water areas to remain at the boil sites. The ice thickness around these open areas will be much thinner than the ice over the rest of the lake. Injury or fatality may result from falling through the ice. Vertex strongly recommends that this danger of thin ice around the boil area be clearly posted at

frequent intervals. Owner assumes all responsibility for operating Vertex aeration systems during winter months.

Noyade attention: exploitation dans des conditions de congélation sur un couvert de glace du lac causera de grandes zones d'eau libre de rester sur les sites ébullition. L'épaisseur de la glace autour de ces zones ouvertes seront beaucoup plus mince que la glace sur le reste du lac. Blessure ou décès peuvent résulter de la chute à travers la glace. Vertex recommande fortement que ce danger de glace mince autour de la zone ébullition être clairement affichés à intervalles fréquents. Propriétaire assume toute la responsabilité pour le fonctionnement des systèmes d'aération Vertex pendant les mois d'hiver.

To prevent risk of freezing the entire water column, AirStations™ should be moved to a shallower portion of the waterway (typically one-half the depth of original placement) and operated there until warmer temperatures return, this will allow warmer water to remain in the lower regions of the waterway and prevent water column freezing.

The airline tubing on shore and the compressor hose must be insulated between the cabinet and the ground. Also, the tubing must enter the water below the winter ice depth.

If you choose to turn off the system for the winter:

- ◆ Unplug the system; no other preparation is required.*
- ◆ In the spring, when the system is restarted, air lines may still contain ice inside the line.
- ◆ One cup of **denatured alcohol** added to each frozen line will melt the ice enough to allow the compressor to push air through the line until heat generated by the compressor melts the remaining ice.
- ◆ Follow the first time and spring start-up procedures.

***It is recommended that all maintenance be done prior to restarting in the spring**

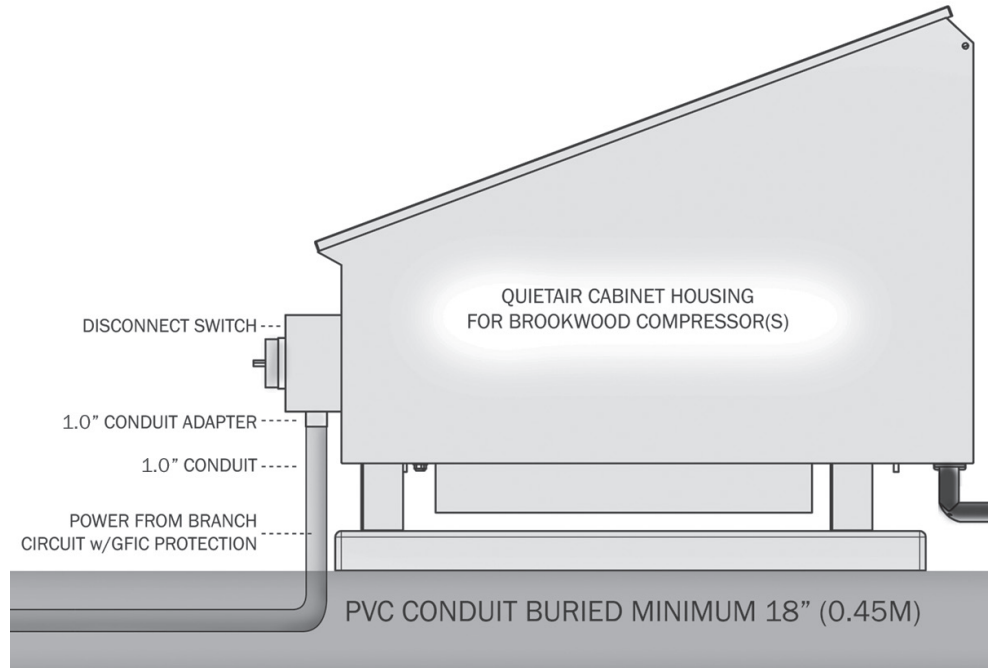
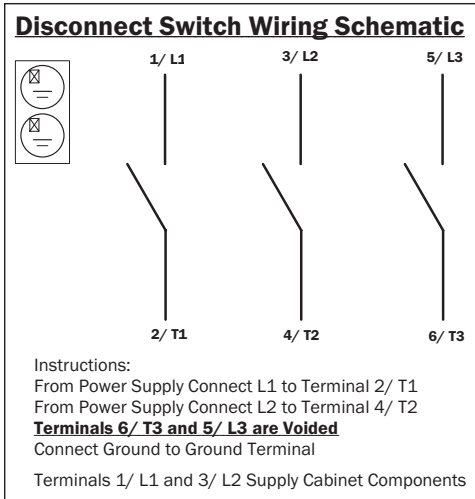

A	AIRSTATION VALVES
B	CABINET FAN AND GUARD
C	CAPACITOR
D	CHECK VALVE
E	COMPRESSOR FAN/GUARD

F	INTAKE FILTER/MUFFLER
G	PRESSURE RELEASE VALVE
H	SOLENOID VALVE
I	PRESSURE GAUGE
J	DISCONNECT SWITCH

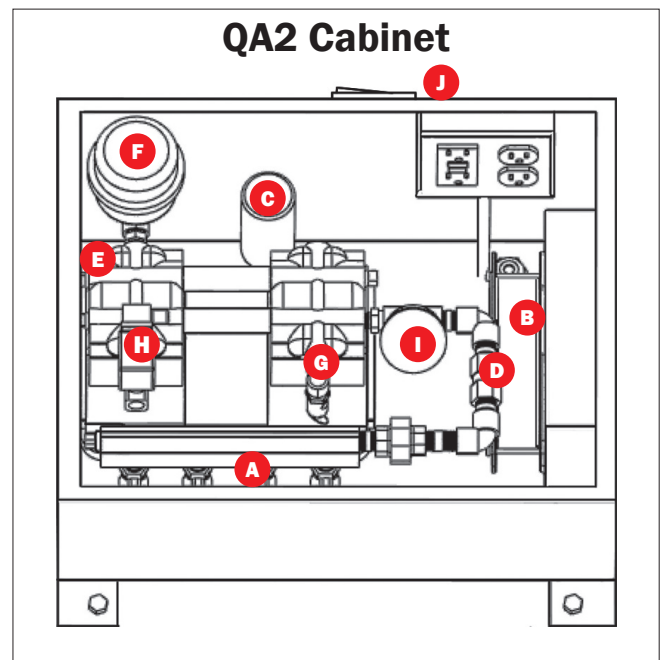
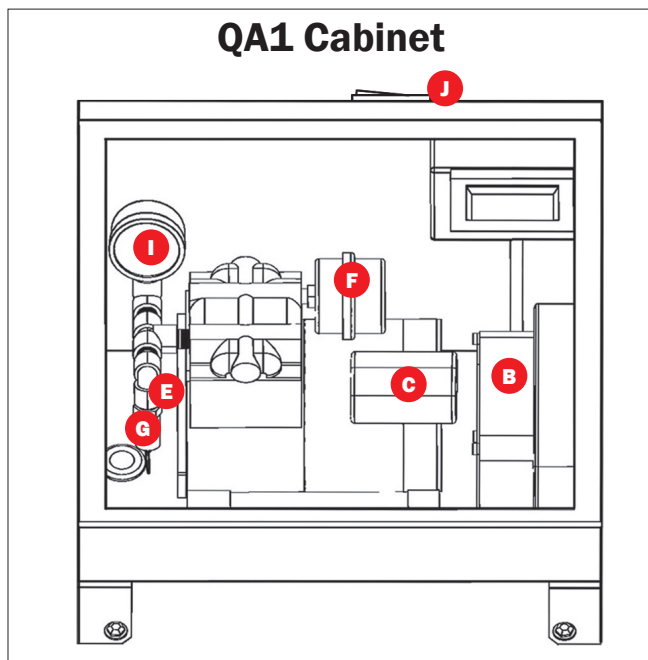

QA3 Cabinet

A	AIRSTATION VALVES
B	CABINET FAN AND GUARD
C	CAPACITOR
D	CHECK VALVE
E	COMPRESSOR FAN/GUARD

F	INTAKE FILTER/MUFFLER
G	PRESSURE RELEASE VALVE
H	SOLENOID VALVE
I	PRESSURE GAUGE
J	DISCONNECT SWITCH

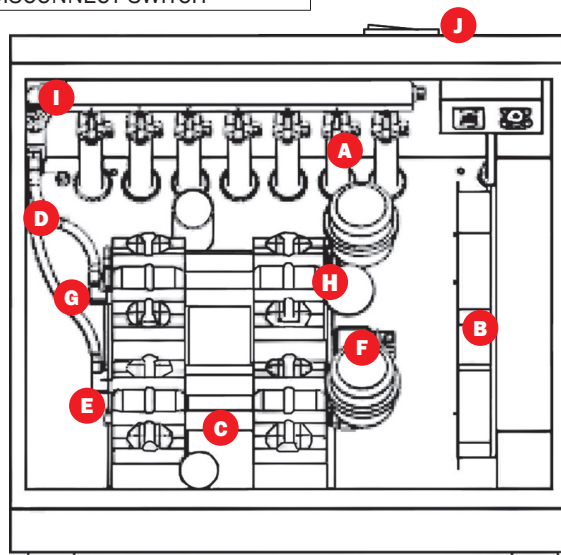
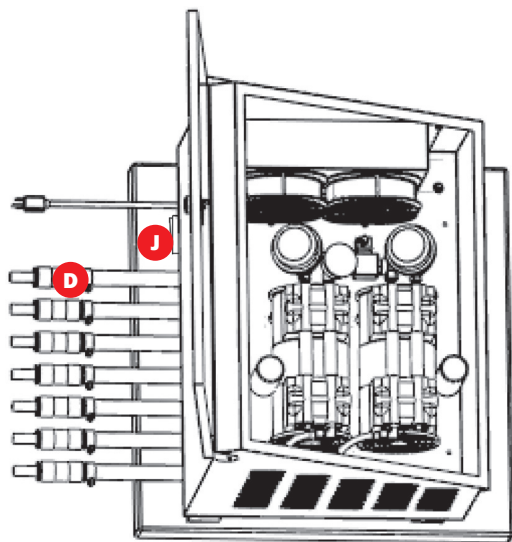

LargeLake Cabinets

A	AIRSTATION VALVES
B	DUAL RECEPTACLE BOXES
C	PRESSURE GAUGE
D	CHECK VALVE
E	COMPRESSOR FAN/GUARD
F	INTAKE FILTER/MUFFLER
G	SOLENOID VALVE
H	SAFETY POP-OFF VALVE
I	CABINET FRAME
J	COOLING FANS
K	DISCONNECT SWITCH

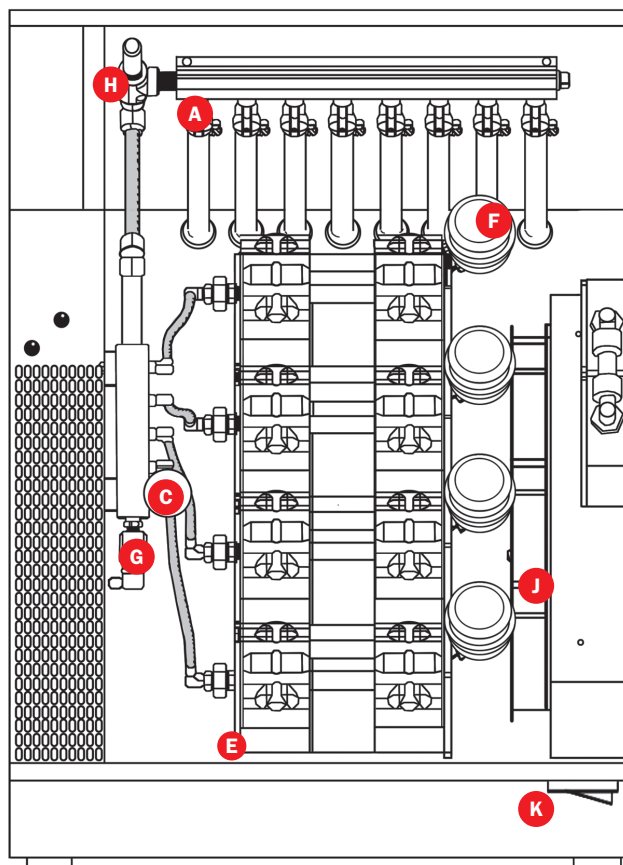
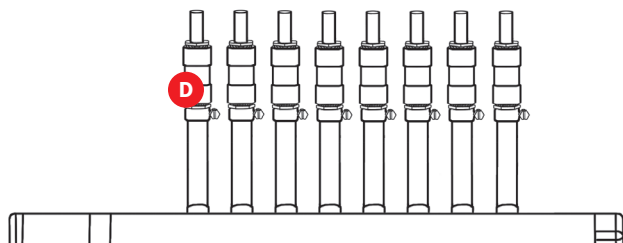

TROUBLESHOOTING GUIDE

ISSUE	CHECK	LIKELY CAUSE	CORRECTION
No bubbles at ANY AirStations. Compressor not running, but cabinet fan is.	Unplug system. Check compressor capacitor wiring for frays or poor connections.	Loose or damages wiring..	Contact Vertex or dealer for instructions.
	No capacitor wiring issues can be seen.	Bad capacitor.	Contact Vertex or dealer for repair/ replacement.
	Capacitor has been replaced.	Compressor is bad.	
No bubbles at ANY AirStations. Compressor and cabinet fan both running.	No air leaks are audible in cabinet. Compressor running louder and possible excessive vibration.	Compressor muffler filter is dirty/clogged or silencer tube in muffler cap is blocked.	Clean or replace filter. NEVER re-install a wet filter. Remove debris clogging silencer tube in muffler cap if blocked.
	Compressor operating normally or making unusual noises. Exhibits reduced pressure/ air flow.	Compressor needs piston rebuild kit and possibly new muffler filter.	Contact Vertex or local dealer with specifications for rebuild kit. Keep muffler filter clean.
No bubbles some, maybe all AirStations. Compressor and cabinet fan are running.	Check for leaks at all connections in line and in cabinet. If none are audible, carefully spray SMALL amount of soapy water onto connections and look for bubbles.	Vibration loosened connection, or cracked fitting.	Tighten loose connection or replace cracked fitting as necessary.
No bubbles at some AirStations, most likely all. Compressor and cabinet fan are running.	Obvious air leak from solenoid valve.	Bad solenoid valve.	Call Vertex or dealer for repair/ replacement.
No bubbles at some, but not ALL AirStations. Compressor and cabinet fan are running.	All valves in cabinet are wide open.	Improper "balancing" of AirStations.	See "AirStation Balancing" section for instructions to balance AirStations.
	Valves in cabinet are "balanced" and no leaks are evident.	Compressor is losing compression and needs piston rebuild kit.	Contact Vertex or dealer with compressor specifications for rebuild kit. Keep muffler filter clean.
Large rolling bubbles instead of fine bubbles at surface above one or more AirStations.	Inspect each AirStation for malfunction.	Diffuser membrane damaged, or AirStation fitting broken.	Call Vertex or dealer for repair/ replacement.
Air coming out of pressure relief valve.	High pressure reading on gauge. Inspect AirStations and tubing for clogging.	All valves closed too much.	Rebalance air flow to AirStations.
		AirStations partially blocked up.	Regular disc flexing not performed. Flex discs 2 times per year to help avoid clogging.
	Low pressure reading on gauge. AirStations not clogged.	Bad pressure relief valve.	Contact Vertex or local dealer for repair/ replacement.
Compressor stops working for periods of time, then restarts.	Inspect fan for proper function.	Compressor overheating due to bad fan.	Contact Vertex or local dealer for fan replacement. Leave top of cabinet open for cooling if possible, otherwise unplug system until fan is replaced.
Compressor shakes erratically and makes load noises.	Check for low voltage while compressor is running under load.	Undersized gauge of supply wires to circuit or cabinet is plugged into extension cord - voids your warranty. Voltage must be checked while the compressor is running at pressure.	If gauge of circuit wiring is incorrect, have electrician replace. NEVER use extension cord to operate system.
	Clogged muffler or blocked silencer tube in muffler cap.	Muffler filter needs replacement, or silencer tube blocked in muffler cap.	Clean or replace filter. NEVER re-install a wet filter. Remove debris clogging silencer tube in muffler cap if blocked.

MAINTENANCE SCHEDULE

 **WARNING/ATTENTION**

To prevent severe shock or electrocution, always turn the power OFF at the service panel before working with electricity. Pour éviter un choc sévère ou d'électrocution, toujours couper l'alimentation au panneau de service avant de travailler avec l'électricité.

Date: _____ Maintenance Performed: _____

Date: _____ Maintenance Performed: _____

Date: _____ Maintenance Performed: _____

Date: _____ Maintenance Performed: _____

Date: _____ Maintenance Performed: _____

Date: _____ Maintenance Performed: _____

Date: _____ Maintenance Performed: _____

Date: _____ Maintenance Performed: _____

Date: _____ Maintenance Performed: _____



1.844.432.4303

vertexaquaticsolutions.com | info@vertexaquaticsolutions.com

Hours of Operation: M-F, 8am-5pm EST

© Vertex Aquatic Solutions